



Common Council Chambers  
8040 S. 6<sup>TH</sup> Street  
Oak Creek, WI 53154  
(414) 766-7000

## COMMON COUNCIL MEETING AGENDA

TUESDAY, SEPTEMBER 17, 2019

7:00 P.M.

Daniel Bukiewicz - Mayor  
Steven Kurkowski - 1<sup>st</sup> District  
Greg Loreck - 2<sup>nd</sup> District  
Richard Duchniak - 3<sup>rd</sup> District  
Michael Toman - 4<sup>th</sup> District  
Kenneth Gehl - 5<sup>th</sup> District  
Chris Guzikowski - 6<sup>th</sup> District

### The City's Vision

*Oak Creek: A dynamic regional leader, connected to our community, driving the future of the south shore.*

1. Call Meeting to Order / Roll Call
2. Pledge of Allegiance
3. Approval of Minutes: 9/3/19

### New Business

4. **Presentation:** Street Lighting Capital Improvement Plan and Feasibility Analysis for LED Conversion.
5. **Motion:** Consider a *motion* to concur with the Mayor's appointment of Kyle Kolhouse, 140 W. Rainbow Ridge, to the Celebrations Commission to fill a 3 year term vacancy expiring 4/2020 (by Committee of the Whole).

### ENGINEERING

6. **Motion:** Consider a *motion* to reject the bids for the PPII Reduction Phase 2 Project in Oakview Subdivision (Project No. 18035)(4<sup>th</sup> District).

### DEPARTMENT OF PUBLIC WORKS

7. **Motion:** Consider a *motion* to approve a two-year extension to the refuse and recycling contract with Advanced Disposal (by Committee of the Whole).
8. **Motion:** Consider a *motion* to approve the installation of additional electrical service for the Lake Vista Park pavilion exterior area, to be installed by Pieper Power in the amount of \$21,350 (by Committee of the Whole).

### LICENSE COMMITTEE

9. **Motion:** Consider a *motion* to grant the various license requests as listed on the 9/17/19 License Committee Report (by Committee of the Whole).

Visit our website at [www.oakcreekwi.org](http://www.oakcreekwi.org) for the agenda and accompanying common council reports.

## **VENDOR SUMMARY**

10. **Motion:** Consider a *motion* to approve the September 11, 2019 Vendor Summary Report in the amount of \$358,701.48 (by Committee of the Whole).
11. **Motion:** Consider a *motion* to convene into Closed Session pursuant to Wisconsin State Statutes to discuss the following:
  - a. Section 19.85(1)(g) to discuss Robert P. Fransway, et al., vs. City of Oak Creek (Milwaukee County Case No. 2018CV005151).
  - b. Section 19.85(1)(e) to consider a proposed term sheet between the City of Oak Creek and Highgate, LLC for the properties at northeast corner of I-94 and Drexel Avenue.
12. **Motion:** Consider a *motion* to reconvene into Open Session.
13. **Motion:** Consider a *motion* to take action, if required.

## ***Adjournment.***

### **Public Notice**

Upon reasonable notice, a good faith effort will be made to accommodate the needs of disabled individuals through sign language interpreters or other auxiliary aid at no cost to the individual to participate in public meetings. Due to the difficulty in finding interpreters, requests should be made as far in advance as possible preferably a minimum of 48 hours. For additional information or to request this service, contact the Oak Creek City Clerk at 766-7000, by fax at 766-7976, or by writing to the ADA Coordinator at the Oak Creek Health Department, 8040 S. 6<sup>th</sup> Street, Oak Creek, Wisconsin 53154.

It is possible that members of and possibly a quorum of members of other governmental bodies of the municipality may be in attendance at the above-stated meeting to gather information; no action will be taken by any governmental body at the above-stated meeting other than the governmental body specifically referred to above in this notice



## COMMON COUNCIL REPORT

**Informational:** Review and provide guidance to staff regarding the SAP document entitled "Street Lighting Capital Improvement Plan and Feasibility Analysis for LED Conversion."

**Fiscal Impact:** As described in the attached analysis and accompanying power point.

- Critical Success Factor(s):**
- Vibrant and Diverse Cultural Opportunities
  - Thoughtful Development and Prosperous Economy
  - Safe, Welcoming, and Engaged Community
  - Inspired, Aligned, and Proactive City Leadership
  - Financial Stability
  - Quality Infrastructure, Amenities, and Services
  - Not Applicable

**Background:** The City's 2017-2020 SAP includes the following goal statement and objectives under the Quality Infrastructure, Amenities, and Services Critical Success Factor:

**OBJECTIVE:** Complete a Feasibility Analysis for Possible Conversion to LED Street Lights

- Complete a lighting inventory;
- Explore energy grants and pilot projects;
- Consult other community best practices/experiences with LED changeout;
- Consult with WE Energies on its maintenance-lease agreement and potential partnership;
- Expand scope to research LED conversion for City-owned lights;
- Finalize a cost-benefit analysis and recommendations for decision-makers.

The scope of the analysis morphed into a dual purpose of both identifying existing capital needs related to the streetlight grid as well as an LED conversion and payback modeling.

At this stage, the staff is seeking Common Council input on directional policy issues such that we can move into the stage of further project planning. Additionally, staff will provide an overview power point presentation at the September 17 Council meeting.

Respectfully submitted:

Andrew J. Vickers, MPA  
City Administrator

Fiscal Review:

Bridget M. Souffrant  
Assistant City Administrator/Comptroller

---

**Attachments:** SAP Document: "Street Lighting Capital Improvement Plan and Feasibility Analysis for LED Conversion"



Initial Public Draft  
September 17, 2019 Common Council

# OAK CREEK

— WISCONSIN —

## Street Lighting Capital Improvement Plan and Feasibility Analysis for LED Conversion



### Policy Team Members:

Andrew Vickers, Ted Johnson, Jennifer Eldredge, Steve Kohnke, Jeff Lynch, Matt Sullivan, Andy Wilken, Dennis Walder (Citizen)

### S.A.P. Critical Success Factor:

Quality Infrastructure, Amenities,  
and Services

# Table of Contents

Executive Summary:.....2

Objective: .....4

Materials, Equipment, and Capabilities: .....4

Inventory: ..... 10

Current Costs and Projected Savings: ..... 124

Greenhouse Gas and CO2 Omissions:..... 178

Funding Options: ..... 18

Conclusions and Next Steps:.....20

## EXECUTIVE SUMMARY

Our Strategic Action Plan (SAP) team conducted a feasibility analysis for possible conversion to LED street lights, a Strategic Action item for 2018 falling in the Quality Infrastructure, Amenities, and Services critical success factor. Our group took a more comprehensive view of this project, digging deeper into the City's street lighting infrastructure as a whole.

The team first undertook an inventory and condition assessment of the poles and lights owned by both the City and WE Energies. The results of this inventory revealed that the City of Oak Creek owns and maintains 2,920 light poles and 3,449 light fixtures. The reason for the discrepancy between poles and lights is because 529 of the poles have multiple fixtures. The City also pays for an additional 1,518 lights owned by WE Energies.

### PROJECT SCOPE AND COST ALTERNATIVES

During the inventory and assessment process, the SAP team identified the following items, in addition to light replacement, as deficiencies in our overall street lighting system: five control cabinets and meters in need of replacement or relocation, 791 direct buried poles in need of replacement, and approximately 12,880 LF of conduit and wire in need of replacement in the Forest Hill Heights and Pioneer Estates subdivisions.

Below is our table of cost estimates for these projects as well as the straight LED conversion for City-owned and WE Energies-owned lights:

<b>Summary of Project Costs</b>		
<b>ITEM NO.</b>	<b>DESCRIPTION</b>	<b>ESTIMATED COST</b>
1	WE ENERGIES LIGHTS TO LED**	\$265,650
2	CITY-OWNED LIGHTS TO LED ONLY	\$1,693,450
3	REPLACE DIRECT BURIED POLES	\$2,096,150
4	SYSTEM UPGRADE FOR FOREST HILL HEIGHTS & PIONEER ESTATES	\$125,275
5	REPLACE CERTAIN LIGHTING CABINETS	\$50,000
<b>Alt A</b>	<b>ITEMS 1-5</b>	<b>\$4,230,525</b>
<b>Alt B</b>	<b>ITEMS 1 &amp; 2 (City-wide LED conversion only)</b>	<b>\$1,959,100</b>
<b>Alt C</b>	<b>ITEMS 2 &amp; 3</b>	<b>\$3,789,600</b>
<b>Alt D</b>	<b>ITEMS 2, 3 &amp; 4</b>	<b>\$3,914,875</b>
<b>Alt E</b>	<b>ITEMS 2, 3, 4 &amp; 5</b>	<b>\$3,964,875</b>
<b>Alt F</b>	<b>ITEMS 1,2,4,5 (excluding direct-buried pole replacement)</b>	<b>\$2,134,375</b>

\*\* only includes up-front capital costs; does not include increase in annual lease fees for first 7 years. (See page 16)

## **ENVIRONMENTAL, ETHICAL, AND FINANCIAL CONSIDERATIONS**

The team also evaluated energy efficiencies (and associated financial savings), maintenance costs, and CO2 emissions. Energy savings for the Oak Creek-owned lights are estimated at 1,356,725 kWh annually. Based on an average run-time of 12 hours per day, and a rate of \$0.10 per kWh, the conversion would save approximately \$135,673 a year in energy costs. The reduced energy consumption would also reduce our carbon footprint by 1,040,000 lbs. of CO2 emissions. To put that in perspective, the EPA Green House Gas Equivalencies Calculator estimates the same amount of CO2 would be emitted by driving your car about 1,162,309 miles in one year.

In 2018, the 1,518 WE Energies-owned street lights cost City taxpayers \$286,902. The City pays WE Energies an average monthly charge of \$15.75 per light pole, which includes the energy to run the light and maintenance costs. If these were City-owned lights and then converted to LED fixtures, our annual energy cost to run these would be \$45,904. Although this project has the fastest payback period and would reduce the City's energy cost by \$240,998 annually, WE Energies currently has no interest in turning these lights over to the City. The current position of WE Energies makes a "city-wide" conversion a significant challenge. As such, this analysis and the pending project(s) make two parallel paths: City-owned light conversion and WE Energies-owned light conversion.

The policy team also examined available grants to help offset the cost of this project. The City qualifies for approximately \$107,000 worth of Focus on Energy grant funding for this project. If the Council advances a comprehensive street light project, staff will conduct a more exhaustive search to ensure the City is applying for all available grant funding.

The light retrofit (City-owned only, excluding WE Energies) portion of this project, item #2 on Summary of Project Costs, has a payback period varying between 6 to 9 years based on installation cost estimates, and percentage of capacity at which the lights are operated.

Staff reviewed several light fixtures capable of supporting a smart lighting system. Smart street lighting enables a whole new class of functionality resulting in considerable reductions in maintenance and energy costs. Examples of those capabilities include, but not limited to: remote dimming, self-diagnostics, smart scheduling, remote shutoff, and emergency control. Based on the criteria outlined in this white paper, and in consideration of a pilot area studied with these fixtures, our team selected the Cree RSW series light. This fixture not only meets all of our criteria, and is considerably less expensive than the LED fixtures we currently specify, they are also manufactured locally in Racine, WI. Costs for the selected fixture are included in item #2 on Summary of Project Costs.

## **PROJECT SCOPE AND FUNDING RECOMMENDATIONS:**

*As this is only a Draft Analysis at this time, this section will be completed after discussions with the Council on policy considerations under "Conclusions and Next Steps" on pages 20-21.*



## OBJECTIVE

The purpose of this SAP analysis is to determine the financial feasibility of upgrading the all street lighting from High Pressure Sodium (HPS) to a more energy efficient LED fixture. It should be no surprise to anyone that using less energy not only reduces your energy bills, but also reduces your carbon footprint. However, until recently, prices and fixture availability made this cost prohibitive for the City of Oak Creek, and other similarly-situated local governments.

In addition to examining a straight retrofit of our existing street lights, the SAP team looked at the street lighting system as a whole. Additional items the team investigated and considered as part of a more comprehensive City capital project included cabinet replacement/relocation, pole replacement, cable upgrades, and the cost associated with smart pole technology.

The five significant benefits the City of Oak Creek would achieve with this project are:

### **Energy Savings**

- Greater system efficiency
- Maintained lighting levels

### **Maintenance Cost Savings**

- 20 year service life
- No lamp changes, no ballast changes

### **Improve Safety & Visibility**

- Enhanced optics
- Better color rendering (CRI) improves visibility

### **Lower Environmental Impact**

- Lower CO2 emissions
- Minimize light pollution

### **Greater Asset Management**

- Remote monitoring and metering capabilities
- Operational control with instant on, manual, or scheduled dimming

## MATERIALS, EQUIPMENT, and CAPABILITIES

### **Fixture Selection:**

Our team had several criteria when looking for a suitable replacement fixture for the existing HPS fixtures located throughout the city.

1. Must have at least ten years of experience manufacturing LED roadway light fixtures;
2. Fixture must maintain at least 92% of initial lumens at 50,000 hours;

3. Fixture must have a minimum of 10kV of Surge protection and shall be tested in accordance with IEEE/ANSI C62.41;
4. Must have a 7-pin photocell receptacle meeting ANSI C136.41, which is compatible with today's smart pole technology and potential adaptation/integration with future technologies;
5. Fixture must have a minimum of 10 year warranty for defects in material and workmanship from date of original purchase;
6. Fixture must accept input of 480 volts which is what feeds the majority of city owned lights as well as 208/277 volts which is the voltage in some of the systems;
7. Fixture should be light weight and easy to install;
8. Reasonably priced;
9. Must have local technical/sales support and manufacturing; Wisconsin will be considered a plus.

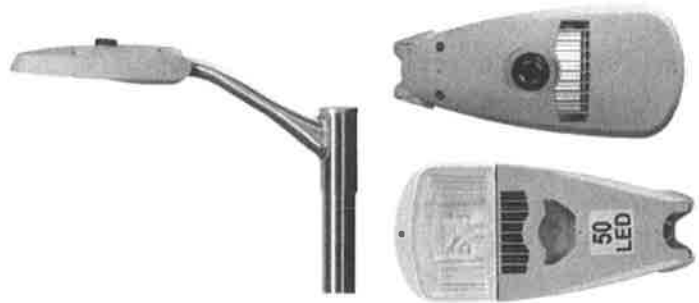

Based on the following criteria, our team recommends the Cree RSW series light shown above. This fixture not only meets all of our criteria, but it is also manufactured locally in Racine WI. Note: the above fixture represents only the “roadway-type” fixture that represent the large majority of City-owned lights, and what most if not all the WE Energies lights would be converted with (if acceptable to WE Energies). The City would also need to select a decorative post-top residential and a decorative commercial fixture as well.

## Cabinet Replacement

While conducting our street lighting inventory another task included identifying the control cabinets and meters which served the street lights in particular areas. During this process five cabinets were identified as needing replacement or relocation. The cabinets that would require replacement are:

1. Cabinet #7 Located at 9080 S. Howell;
2. Cabinet #5 Located at 7628 S. Howell;
3. Cabinet #77 Located East of Oak leaf Path Bridge on the South side of Ryan Rd.;
4. Cabinet #12 Located in the backyard of property 310 E. Stuart Drive;
5. Cabinet #58 Located at the intersection of Puetz and Nicholson Roads.

Based on recent pricing Engineering has received for the installation of new cabinets, the City should estimate \$10,000 per cabinet.

## Pole Replacement

Although the majority of the City-owned poles are aluminum, there are three distinct differences with the way they are installed. Those differences are as follows:

1. **Direct Bury:** These types of installations are done by augering a hole approximately six feet in the ground and simply placing the pole into the hole and backfilling. What is problematic with this type of installation is that two feet below the ground two holes are drilled into the pole directly across from each other for the light fixtures to be wired. This compromises the structural integrity of the poles. As the poles age, they crack at the two holes used for wire entry, leaving the poles supported by only two feet of ground, making them very unstable.

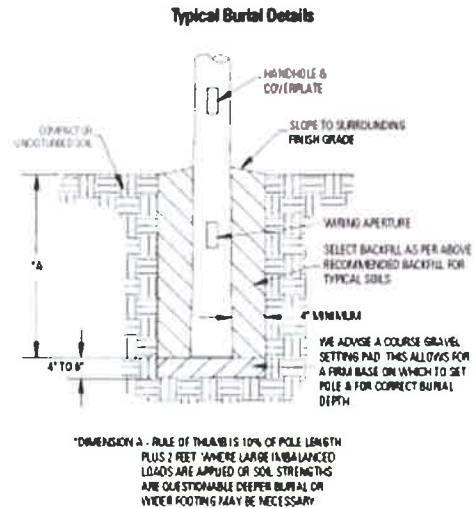

2. **Base Mount:** Base-mounted poles are poles attached to a concrete base that is poured below the frost line which secures it and prevents it from heaving in the winter. Base-mounted poles have breakaway bolts, making them safer for a motorist if they were to collide with one. However, once hit, the pole is typically severely damaged, and the bolt holes used to fasten the pole to the base is destroyed. The pole's structural integrity is compromised and requires replacement. Base-mounted poles also lack the additional space that makes wiring and mounting other items, like outlets and transformers, easier for the electrician.



3. **T-Base Mount:** T-Base mounted poles are our preferred method of installation for street lighting. Like base-mounted poles, they are mounted to a concrete footing buried five feet below grade. They also have breakaway bolts that make them safer for motorists in a collision. Other advantages to this type of installation are more accessible wiring that makes for easier installation and repair, and additional room in the base to mount a step down transformer or other needed equipment. We have also found that this type of pole mount tends to break the base section when hit, saving a considerable amount of money by only requiring replacement of the base and not the entire pole.

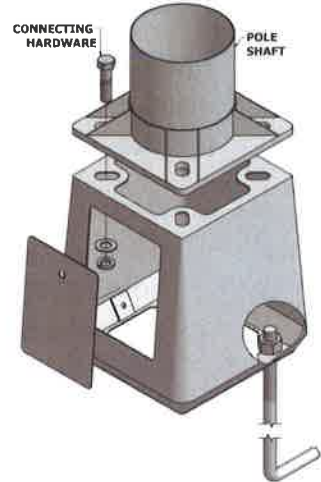

The existing base-mounted poles can be retrofit to T-Based poles by purchasing the correct T-Base to fit the pole, removing and reinstalling the pole, and reconnecting the wiring. It would be advisable to do these in groups, or there would be differences in the heights of the poles.

### Cable Upgrades

When evaluating this project as a whole, one of the components considered was if there were any known deficiencies in our underground wiring. Both the City Electrician and City Engineers agreed that portions of the wiring in two distinct areas are substandard and need replacement. These areas are located in the Pioneer Estates and Forest Hill Heights subdivisions. The two maps shown below illustrate the areas of direct-buried wire within the two subdivisions that have failed in the past. There is approximately 12,880 LF of conduit and wire that would need to be replaced having an estimated cost of \$125,275.

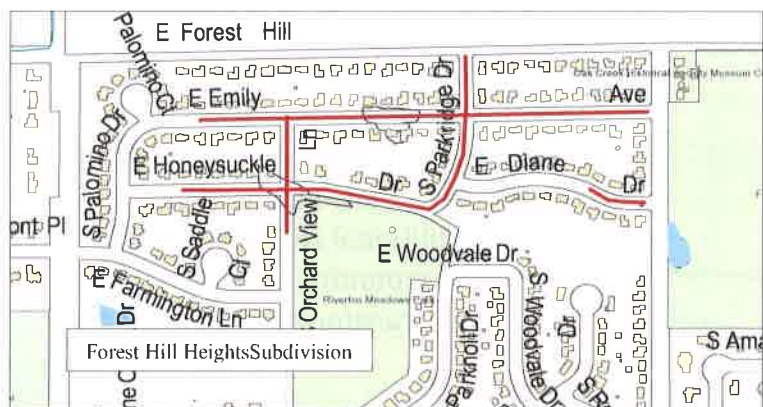
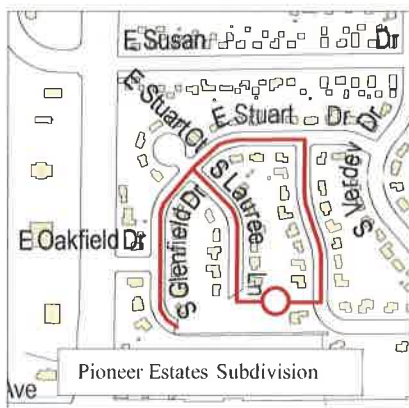

## Smart Lighting

Smart lighting is an option on some LED lights available on the market today. Our Policy Analysis Team recommends a light fixture that can take advantage of these smart features. Smart street lighting functionality is made possible by a node and gateway facility that can be added to the street lighting system.

Nodes are simply a communication device located on the LED fixture that allows the light to be networked. The nodes communicate through a gateway that enables the system to interact with computer programs within the system. Below is a picture of a light with a seven pin node attached to the top, and a basic diagram of a street lighting network.

1. **Power metering:** It is possible to generate highly accurate reports of energy usage with smart lighting. Groups of “virtual meters” can also be easily created.
2. **Adaptive Dimming:** Individual lights or groups of lights can be dimmed based on a programmable schedule or by events or motion sensor inputs.
3. **GPS:** GPS capabilities provide accurate location data of fixture location.
4. **Maintenance Alerts:** The lights can proactively send alerts when they are malfunctioning or damaged.



Below is a basic overview of how the system communicates and is controlled.

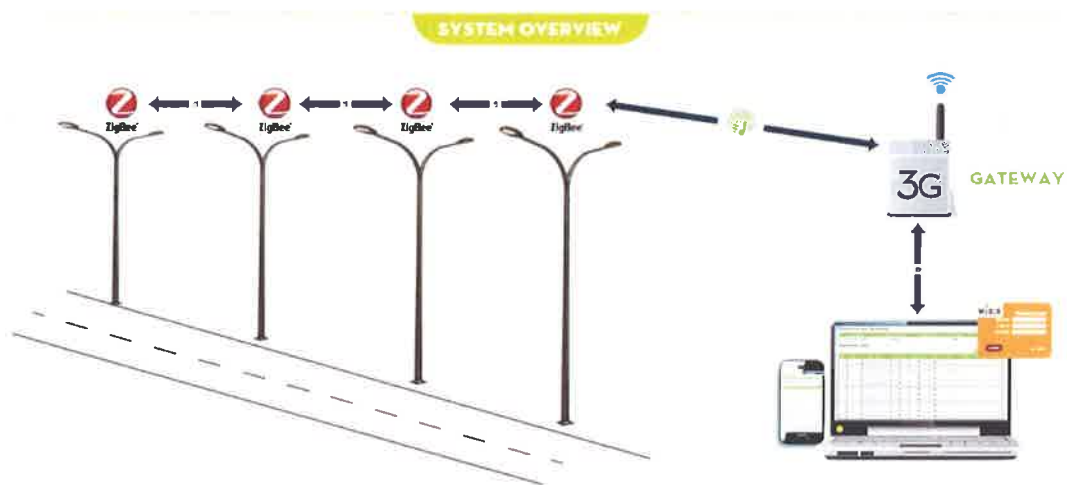

Having this network in place also allows for additional, future options, purchased as separate programs, to work with the system. These options rely on data transmission to work. Therefore, once the smart light network is in place, these

functions can piggy-back on the same network. Establishing a smart light framework opens the door for many future options. Some of these options include:

**Moisture Sensors** – Different temperatures of white light cut through fog better than others. This sensor can be used to alter the light temperature in the presence of fog.

**Speakers** – Play music or city announcements.

**Digital Signage** – Much like the Visix message centers throughout City Hall, these screens could display any custom message or image we choose.

**Traffic Sensor** – This sensor detects the unique, but untraceable, ID from cell phones and other electronic devices and “follows” it through the City so that patterns can be determined. This capability could allow for better traffic signal timing, or even integrate with digital signage to suggest alternate routes.

**Air Quality Sensor** – Detects smog, allergens, and pollutants.

**Parking Sensor** – Can be configured to monitor parking both on streets and in lots to determine how many and the location of empty parking spots. It can also be used for traffic enforcement, watching the spaces and alerting when a car hasn’t moved for a certain amount of time.

**Emergency Services Warning** – The street lights could display a warning, typically a red flashing light, when emergency vehicles are approaching.

**Electric Vehicle Charging** – Because the smart lighting controls can accurately monitor energy usage, it can discern what energy is used for the light and what energy is used for the vehicle charging and can thus charge the owner appropriately.

**5G small cells** – The new 5G cellular technology has a far shorter range than existing 4G networks. This necessitates the installation of far more antennae. Smart light poles can piggy back the 5G data onto the existing data transmission allowing the City to lease this bandwidth. Note that when recently speaking with Verizon they stated they would not pay, nor give a bill credit, for us allowing them to put their small cells on our poles. Their position is that once the market demands 5G signal public pressure will force us to install them, so they won’t spend money to get us to do it sooner.



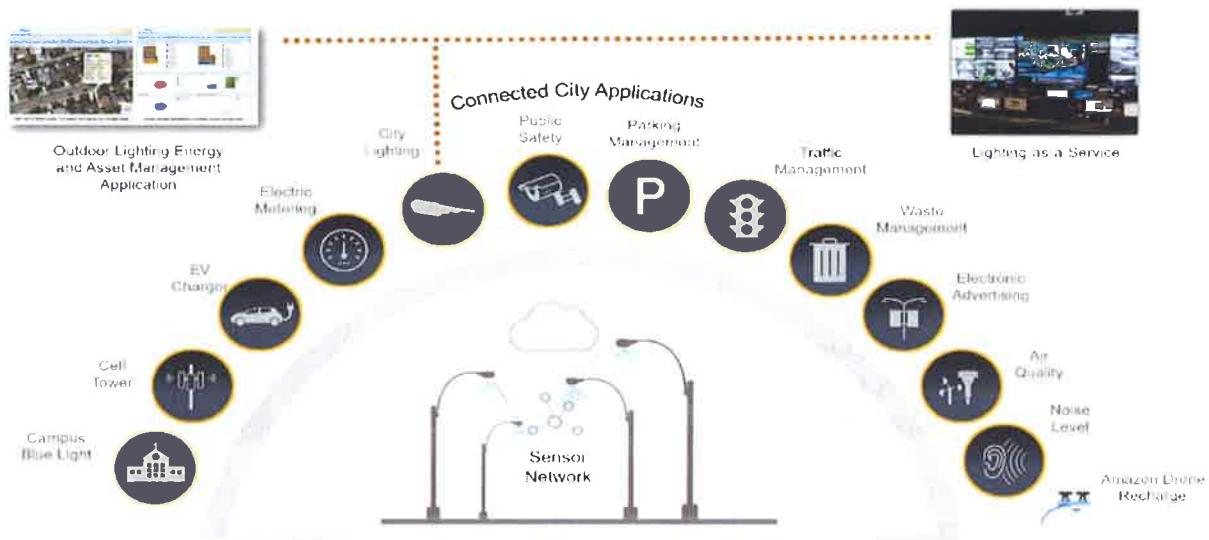

## Pilot Area

The Policy Team selected a pilot area, located in South Branch Business Park, to evaluate some basic smart lighting technology. The pilot area consists of the first 10 lights east of 27<sup>th</sup> Street on Preserve Drive. Staff is currently monitoring the operation of that system. Basic functionality of the system includes power metering, adaptive dimming control, GPS capabilities, and maintenance alerts. Currently, certain staff are in training with CIMCON, the manufacturer of the nodes we are testing, and have received the basic and more advanced training on the system.

## INVENTORY

DPW crew were tasked to go throughout the City and inventory every street light pole owned by the City of Oak Creek with a Trimble GPS locator. The data that was collected for every pole included:

- Photograph of the pole;
- Location Coordinates;
- Control Cabinet Number;
- Wattage of Fixture;
- Pole Height;
- Pole Type:
  - Wood;
  - Aluminum.
- Closest Address;
- Installation Type:
  - Direct Bury (currently prohibited for new installation in the City);

- Concrete Base Mounted;
- T Base Mounted to concrete base.
- Head Type:
  - Single Head;
  - Double Head;
  - Hat Fixture(oldest resident type fixture).
- Fixture Type:
  - LED (Light Emitting Diode);
  - HPS (High Pressure Sodium);
  - MV (Mercury Vapor).

The image at-right shows collection data for one of the inventoried poles.

Once the inventory was completed, all the lights were mapped and the data were sorted.

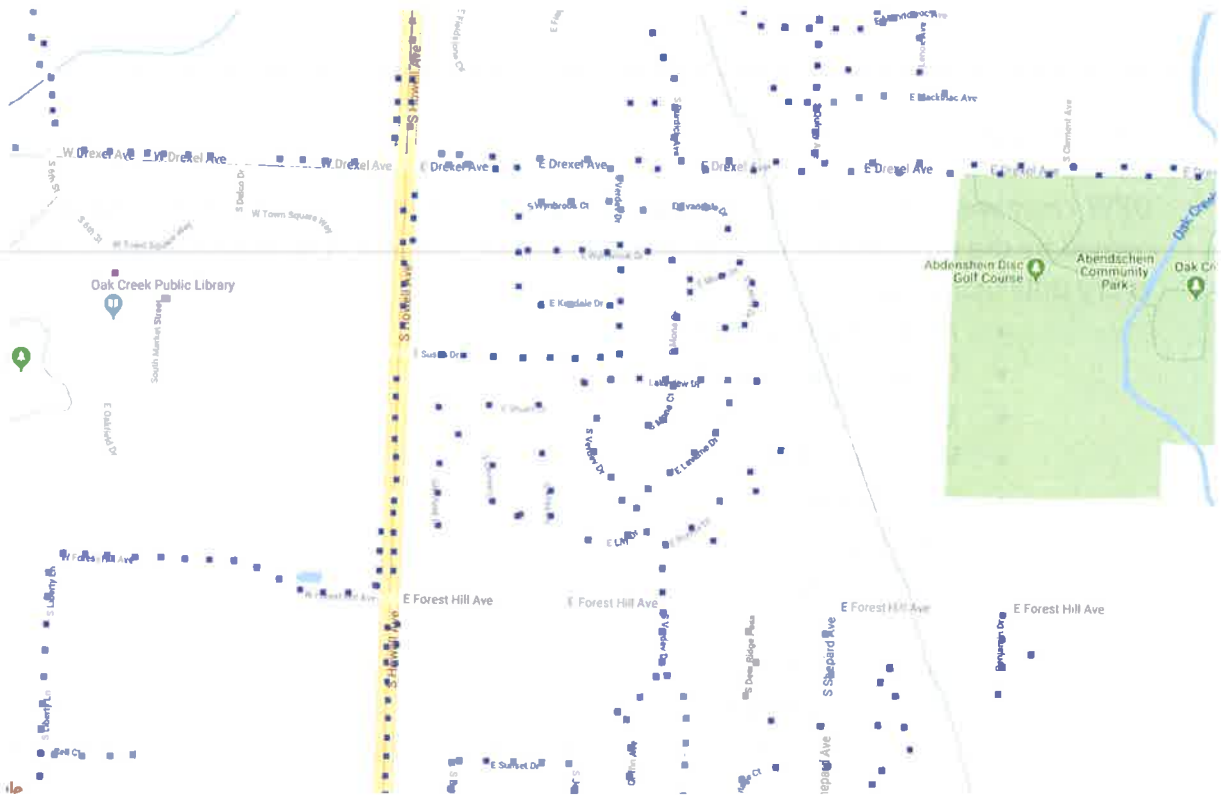
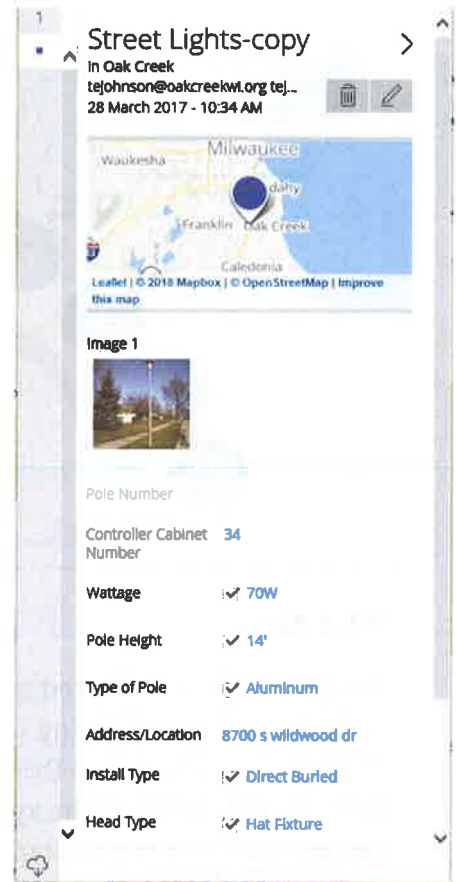



Currently, the City of Oak Creek maintains a total of 2,920 light poles, and a total of 3,449 fixtures because 529 of these light poles are dual-head. Out of the 3,449 fixtures, 3,079 are HPS, and 370 have already been upgraded to LED. Below is a chart summarizing the data collected:

<b>Fixture Type</b>	<b>70W</b>	<b>100W</b>	<b>150W</b>	<b>200W</b>	<b>250W</b>	<b>unverified</b>	<b>Total</b>
HPS	613	890	1240	76	123	127	<b>3079</b>
LED	8					368	<b>370</b>
						<b>Total</b>	<b>3449</b>

<b>Pole Height</b>	<b>Base Mount</b>	<b>Direct Bury</b>	<b>T Base Mount</b>	<b>Total</b>
<b>14'</b>	276	170		446
<b>18'</b>	650	311		961
<b>20'</b>	22	79		101
<b>25'</b>	416	142		558
<b>30'</b>	748	89	17	854
			<b>Total Poles</b>	<b>2,920</b>

<b>Type</b>	<b>Fixtures Per Pole</b>	<b>Qty</b>	<b>Total Fixtures</b>
<b>Double Head</b>	2	529	1058
<b>Hat</b>	1	839	839
<b>Single Head</b>	1	1488	1488
<b>Unverified</b>		64	64
		<b>Total</b>	<b>3,449</b>

### **Current Light Fixture Styles in City**

The City of Oak Creek currently owns three types of light fixtures: hat fixtures, decorative “post-top” residential fixtures, and roadway light fixtures. Each of these fixtures are shown in this section.



The photo to the left represents a hat fixture. There are currently 839 hat fixtures throughout the City. Hat fixtures are typically located in the older neighborhoods, and are almost always installed on direct bury poles.

The City began using decorative post-top residential fixtures (see right) approximately ten years ago. Currently, 616 of these fixtures are located in the newer subdivisions in Oak Creek.



Roadway lighting (see left) is generally what you think of as a typical street light fixture. These lights are located on main roadways, but are also located in some residential areas. The City currently owns 1,944 roadway light fixtures, and all WE Energies-owned lights are this style. This category includes the City's "decorative commercial" style fixtures as well.

The map below shows the general location of all three styles of City-owned lights.

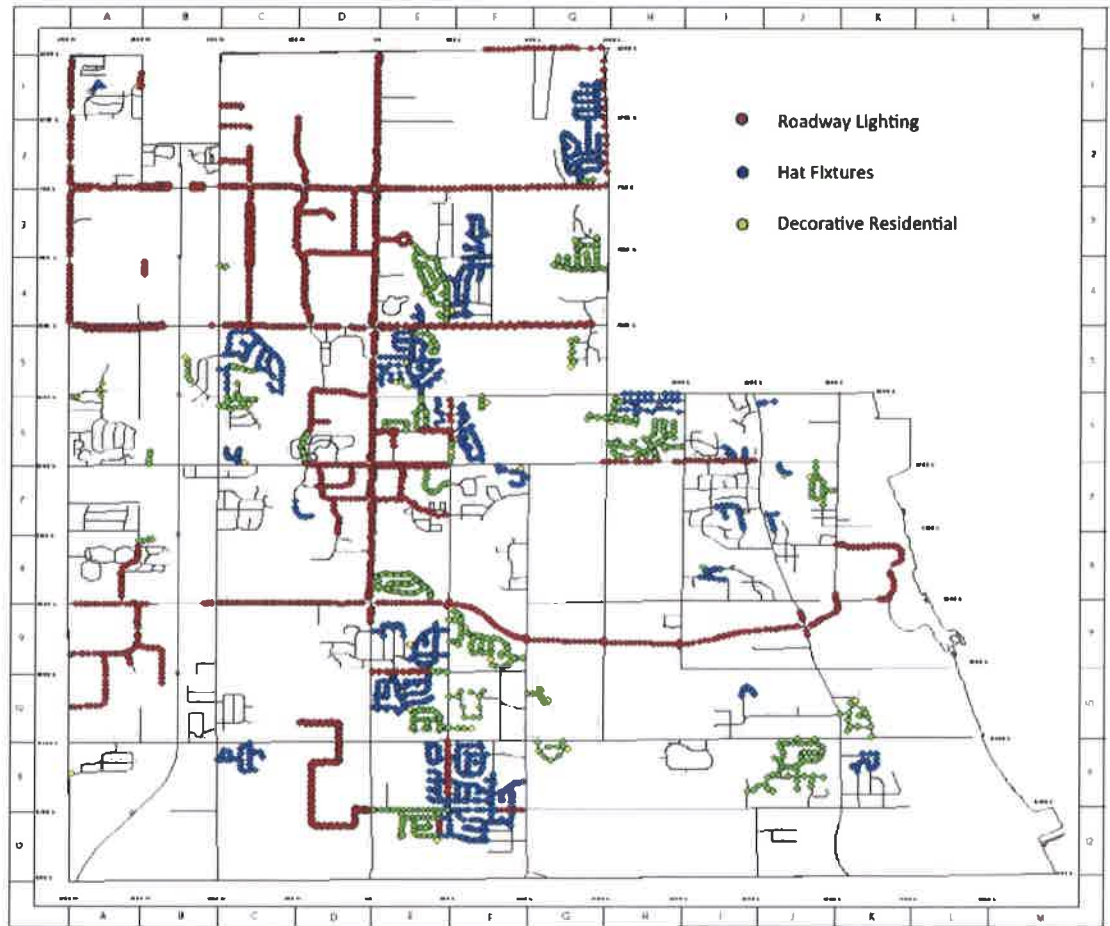

## CURRENT COSTS AND PROJECTED SAVINGS

### Oak Creek-Owned Lights

The City currently pays \$199,519 for energy for the 3,079 City-owned HPS fixtures. This figure is based on an average of twelve hours of run time per day. If the City were to upgrade to all LED fixtures, the financial savings would be approximately \$135,673 per year given reduced energy consumption. The City also budgets another \$80,000 per year for street light maintenance, and although these lights have a low failure rate, it would be pure speculation to assume all of the \$80,000 as maintenance savings. We also have between 3-5 hit and run incidents per year for light poles; the cost for these ranges from \$2,500 to \$5,500 depending on the number and type of fixtures on the pole.

Based on our estimated project cost for LED-only (no additional system maintenance) conversion of \$1,586,450, and using a conservative \$40,000 maintenance savings annually, we anticipate a payback in 9 years.

City of Oak Creek, WI Street Lighting Conversion						
Project Summary Sheet						
Oak Creek Project Team Cost Estimate						
	Annual Costs & Savings			Final Project Costs		
	Existing	New	Savings			
Annual kWh	1,995,192	638,467	1,356,725		Total Retrofit Cost	\$1,693,450
Annual Energy	\$199,519	\$63,847	\$135,673		Total Rebate Incentive	\$107,000
Annual Maintenance	\$80,000	\$40,000	\$40,000		Net Project Cost	\$1,586,450
Annual CO2 Emissions (lbs)	1,045,481	334,557	710,924		Sales Tax % Applied	0.00%
20 Year Costs & Savings				Simple Payback Years		
	Existing	New	Savings		Total Project Cost	Net Project Cost
20-Year Energy	\$3,990,384	\$1,276,934	\$2,713,450	Energy Savings Only	12.48	11.69
20-Year Maintenance	\$1,600,000	\$800,000	\$800,000			
20-Year Energy + Maintenance	\$5,590,384	\$2,076,934	\$3,513,450		Simple Payback Years	
Loan Payments	\$0	\$0	\$0		Total Project Cost	Net Project Cost
Rebate Incentive	\$0	(\$107,000)	\$107,000	Energy and Maintenance Cost	9.64	9.03
Grand Total	\$6,881,612	\$1,487,058	\$5,394,554			
Assuming conversion of all 3079 HPS lights to LED using a local subcontractor						
Applied rebates from Focus on Energy Rebates						
Based on \$0.10/kwh rate						

## We Energies-Owned Lights

There are currently 1,518 WE Energies-owned street lights that cost the City \$286,902 annually. The City pays We Energies an average monthly charge of \$15.75 per light, which includes the energy and maintenance/repair costs. If these were City-owned lights, and converted to LED fixtures, our annual energy cost to run these would be \$45,904; a savings of \$240,998 annually.

It is estimated that it would cost the City approximately \$759,000 for the initial upgrade to convert these lights to LED fixtures. Energy savings from this project would pay for this conversion in about 3.1 years. **Although this project has a superb payback period, and would reduce the City's energy cost by \$240,998 annually, WE Energies currently has no interest in turning these lights over to the City of Oak Creek. This stance is very unfortunate for City taxpayers.** Other states require utilities to sell or turn over street lighting to local municipalities. This is a popular practice in the northeastern United States, but is not an option for Wisconsin municipalities unless there is a legislative fix; incredibly unlikely.

The only viable option is to request WE Energies to change out their 1518 HPS fixtures with LED fixtures. Again, these are standard highway-type light fixtures mounted on WE

Energies wooden utility poles, so it is simply a matter of WE Energies' crews replacing the HPS fixtures with LED fixtures of similar style.

Under its current policy WE Energies changes out existing fixtures to LED for a fee of \$175 per unit. The monthly charge on the LED fixture is then \$18.19 per month for the first 7 years, at which point it is reduced to \$10.01 per month thereafter.

Thus, the City's costs would be higher due to the fixture change over ("Year 1a" cost of \$265,650) and the first 7 years of service, but then reduce significantly after that, with a calculated breakeven point within 13 years. Beyond the 13-year breakeven point, the City savings would be \$104,560 per year. These data are presented in the table below.

Year	LED Cost	Cumulative LED Cost	HPS cost	Cumulative HPS Cost	Cost Savings	Cumulative Cost Savings
1a	\$265,650	\$265,650	\$0	\$0	-\$265,650	-\$265,650
1b	\$331,349	\$596,999	\$286,902	\$286,902	-\$44,447	-\$310,097
2	\$331,349	\$928,348	\$286,902	\$573,804	-\$44,447	-\$354,544
3	\$331,349	\$1,259,697	\$286,902	\$860,706	-\$44,447	-\$398,991
4	\$331,349	\$1,591,046	\$286,902	\$1,147,608	-\$44,447	-\$443,438
5	\$331,349	\$1,922,395	\$286,902	\$1,434,510	-\$44,447	-\$487,885
6	\$331,349	\$2,253,744	\$286,902	\$1,721,412	-\$44,447	-\$532,332
7	\$331,349	\$2,585,093	\$286,902	\$2,008,314	-\$44,447	-\$576,779
8	\$182,342	\$2,767,435	\$286,902	\$2,295,216	\$104,560	-\$472,219
9	\$182,342	\$2,949,778	\$286,902	\$2,582,118	\$104,560	-\$367,660
10	\$182,342	\$3,132,120	\$286,902	\$2,869,020	\$104,560	-\$263,100
11	\$182,342	\$3,314,462	\$286,902	\$3,155,922	\$104,560	-\$158,540
12	\$182,342	\$3,496,804	\$286,902	\$3,442,824	\$104,560	-\$53,980
13	\$182,342	\$3,679,146	\$286,902	\$3,729,726	\$104,560	\$50,580
14	\$182,342	\$3,861,488	\$286,902	\$4,016,628	\$104,560	\$155,140
15	\$182,342	\$4,043,831	\$286,902	\$4,303,530	\$104,560	\$259,699
16	\$182,342	\$4,226,173	\$286,902	\$4,590,432	\$104,560	\$364,259
17	\$182,342	\$4,408,515	\$286,902	\$4,877,334	\$104,560	\$468,819
18	\$182,342	\$4,590,857	\$286,902	\$5,164,236	\$104,560	\$573,379
19	\$182,342	\$4,773,199	\$286,902	\$5,451,138	\$104,560	\$677,939
20	\$182,342	\$4,955,541	\$286,902	\$5,738,040	\$104,560	\$782,499



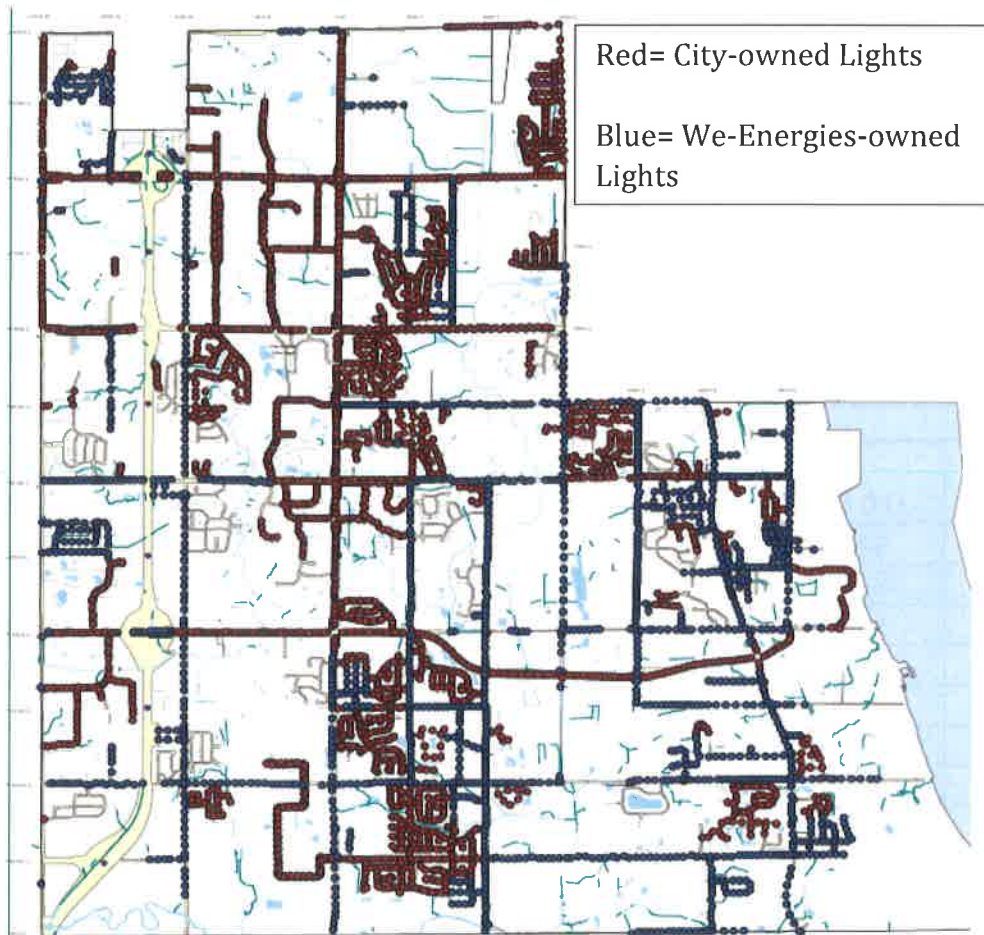

The WE Energies vs. City-owned lighting conversion comes down to a question of lighting consistency. Does the City wish to have more uniformity of street lighting, and is the City willing to include WE Energies in the LED conversion payback analysis despite its longer payback?

One potential alternative the City could consider is a more selective conversion of WE Energies lights. Long stretches of main arterial roadways featuring WE lights could be left as is, or perhaps changed out in the future. Other areas where WE lights and City lights are more interspersed could be targets for conversions such that a light consistency is promoted within a subdivision or certain geographic area. Taking a more selective approach could improve the overall payback model when including the selected WE lights with the City lights.

## GREENHOUSE GAS AND CO2 OMISSIONS

With growing concerns about global warming we felt it was important to not only be fiscally responsible with taxpayer's money but also to demonstrate Oak Creek's stewardship to the environment. By converting our existing HPS lights to LED fixtures, the City will reduce its carbon footprint by 1,040,000 pounds of CO2 emissions. To help put this into perspective, the sum of the greenhouse gas emissions Oak Creek would be reducing is equivalent to:



All three of these examples send a powerful message about the reduction of pollution this project would have on our environment. Regardless of one's opinion on global warming, it is hard to argue the net positive of putting fewer pollutants into our environment, and burning less fossil fuels.

## FUNDING OPTIONS

### ESCO

An energy service company (ESCO) is a company that provides comprehensive energy solutions to its customers including auditing, redesigning and implementing changes to the ways the customer consumes energy. The main goal of an ESCO is improved efficiency. Typically compensation to the ESCO is performance-based so that the benefits of improved energy efficiency are shared between the client and the ESCO.

Typically an ESCO will perform an energy audit or feasibility study to determine if it is a viable project for both parties. If it is determined to be a worthwhile project, the ESCO will offer a turnkey solution which is paid for by the projects energy savings based on terms negotiated in a performance contract. They will also monitor the project for the lifetime of the agreement to insure that you are maximizing energy performance. Certain ESCOs require the

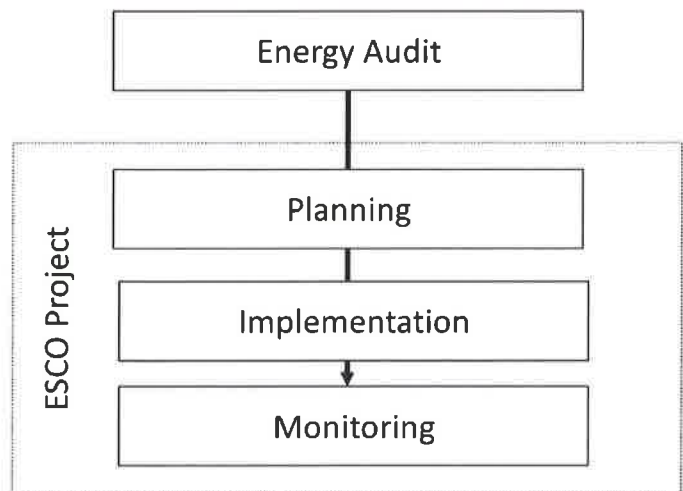

municipality to access their own capital (i.e. borrow) for the project, and others may finance the project and pay themselves back through the energy savings.

### **Performance Contracting**

The City has had discussions with two firms specializing in performance contracting (i.e. the ESCO concept), Tanko Lighting and Siemens, Inc. Both firms would be viable options if the City was looking to rely on a guaranteed energy savings for the project, albeit, at higher construction project management fees than if the City were to use a traditional contractor or manage the project itself. Further, unlike certain ESCOs, these performance contracting firms require the City to access its own capital for up-front project costs.

### **Municipal Bond**

The City of Oak Creek could potentially fund this project by issuing a municipal bond. Oak Creek currently holds an Aa2 bond rating from Moody's and would not have a problem securing a municipal bond to finance this project. However; unlike the ESCO model, the City would be tasked with the energy audit, planning, implementation and monitoring of the project to insure its optimum performance. On the other hand, municipal bond markets are at historic lows and now is the ideal time to borrow from an interest rate perspective.

### **Potential Grants**

The policy team has confirmed with Focus on Energy that the City would qualify for approximately \$107,000 dollars-worth of grant funding for this project. If Council approves this project, an updated search would be conducted to insure we were capturing all the grant funding available.

### **Funding through CIP**

Capital Improvement Project (CIP) funding is a possibility for this project; however at the estimated cost, it would not seem practical to support the project through the CIP budget given levy limit and expenditure restraint limitations.

### **Creation of a special fee on the property tax bill for public street lighting (energy, operations, and maintenance costs)**

Wisconsin State Statutes enable municipalities to impose a "fee" on properties to cover the costs of street lighting energy, operations, and maintenance. Communities can (and some already do) charge back the street lighting costs as a "special charge" per parcel on the property tax bill. City costs are approximately \$715,000 each year for street lighting operation, maintenance, and staffing costs. These costs could be "charged back" to property owners, thereby freeing up general property tax levy capacity for use capital projects including, but not limited to, this street lighting system upgrade and LED conversion project. In sum, this method treats street lighting as its own "utility" with a dedicated funding source to support it coming from the special charges per parcel.



***This alternative has the potential to be a central strategy for the City moving forward.***

If the Council has a strong interest in pursuing this alternative, they could direct staff to perform a more in-depth study of which communities use this alternative, and how they equitably implement it.

### **TID Funding**

A TIF district could support street lighting upgrade costs for infrastructure within a TID (or within ½ mile) boundaries if street lighting is listed as an applicable expenditure in the TIF project plan, if the TIF still has allowable expenditure years, and if the TIF is financially able to support the cost of the upgrade.

### **CONCLUSIONS AND NEXT STEPS**

We feel that based on the projected payback period the LED light project is a viable project. Certainly, the conversion for City-owned lights, but, for consistency, the City should work with WE Energies to convert its lighting, at least in locations where WE lights and City lights are more “interspersed”. This will promote consistency of lighting across the City, albeit, the conversion of WE Energies lights is not as attractive of a return on investment. Next steps for this project would be to establish which project components to be funded, what funding mechanism would appropriate, and method for project implementation.

More specifically, the policy team offer the following questions, and recommends the below next steps:

- 1) Review questions, concerns, and suggestions on this **Draft** Analysis with the Mayor and Common Council;
- 2) Produce a white paper analyzing the policy option of establishing a “fee” for street light operations and maintenance. Get Council direction as to their appetite for this policy alternative;
- 3) Understand the need and importance of replacing direct-bury poles with mounted style. Get Council direction as to the priority of a proactive vs. reactive replacement schedule (the direct-bury replacement costs cannot fairly be included in a cost-benefit analysis of a pure LED Conversion);
- 4) Gain better understanding of WE Energies conversion costs and payback. Council determination if lighting/LED uniformity and eventual savings makes an adequate business case considering an atypically long return on investment with the WE Energies light conversion;
- 5) Finalize Council approach as to scope of project per options and costs Items 1-5;
- 6) Produce an overall payback model including WE Energies and City-owned lights after Council determines their direction as to WE Energies lights;

- 7) Identify the preferred funding alternative and begin planning the project (early coordination with WE Energies is key as well);
- 8) Other ideas and action steps as recommended by the Common Council.

## COMMON COUNCIL REPORT

**Item:** Bid rejection for the PPII Reduction Phase 2 project in Oakview Subdivision.

**Recommendation:** That the Common Council considers a motion to reject the bids for the PPII Reduction Phase 2 project in Oakview Subdivision (Project No. 18035)(4<sup>th</sup> Aldermanic District).

**Fiscal Impact:** None.

**Critical Success Factor(s):**

- Vibrant and Diverse Cultural Opportunities
- Thoughtful Development and Prosperous Economy
- Safe, Welcoming, and Engaged Community
- Inspired, Aligned, and Proactive City Leadership
- Financial Stability
- Quality Infrastructure, Amenities, and Services
- Not Applicable

**Background:** The Private Property Infiltration and Inflow (PPII) reduction construction project for the eastern portion of Oakview Subdivision was advertised for public bid. Three bids were submitted and publicly opened on August 30. Bids were evaluated based on two criteria; to include a total estimated bid price based on unit prices, and to include satisfactory prequalification documentation as outlined in the bid documents. Bids received and the evaluation results are summarized here:

Contractor	Bid	Prequalification Docs
Donovan Services LLC	\$124,649.00*	Not Acceptable
Mid-City Corp.	\$136,435.00	Not Acceptable
Musson Bros., Inc.	\$143,920.00	Not Acceptable

\*Errors in the bid prices

Donovan Services, the apparent low bidder, had errors in their bid that precluded them from being considered any further for contract award. Moreover, all bidders had unacceptable prequalification documents due to missing required information. This was discussed among the design team (City staff, MMSD and our consultant design engineer, OTIE) and it was agreed that the only option is to recommend that the City reject all bids.

The plan, then, would be to proceed on with the other section of the neighborhood ("Group A"), add this project's ("Group B") scope of work with Group A's work, and advertise that larger project as early as possible for construction in 2020. We would work with MMSD and OTIE to enlist a better prequalification process to assure successful construction and would explore the potential for alternate bidding options.

Options/Alternatives: None. There are too many issues with the bids and related documents submitted to responsibly award the contract.

---

Respectfully submitted:



Andrew J. Vickers, MPA  
City Administrator

Prepared:



Michael C. Simmons, P.E.  
City Engineer

Fiscal Review:



Bridget M. Souffrant  
Assistant City Administrator/Comptroller

---

Attachments: Graphic on Work Areas A & B

# Oakview

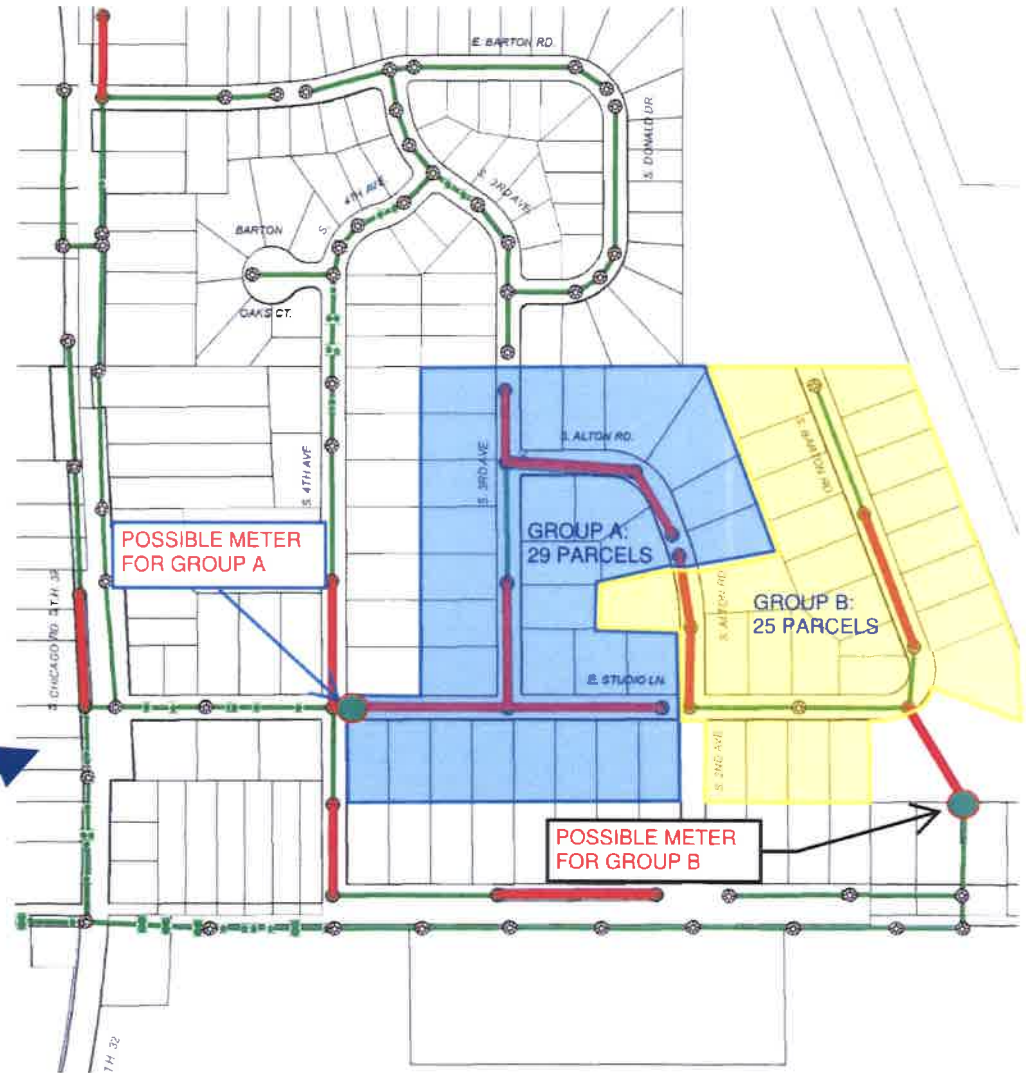

## COMMON COUNCIL REPORT

**Item:** Two-year extension of refuse and recycling collection contracts.

**Recommendation:** Approve a two-year extension to our trash and recycling contract with Advanced Disposal.

**Fiscal Impact:** This would be paid for out of fund 11 Solid Waste (levy-funded). Cost for fiscal years 2020 and 2021 are listed in the table below.

	2019	2020	2021
	(Current Contract)		
Annual Trash	\$897,130.08	\$910,269.86	\$946,512.00
Annual Recycle	\$277,421.76	\$380,016.00	\$398,160.00

The total fiscal impact from 2019 to 2020=\$115,735.02

The total fiscal impact from 2020 to 2021=\$54,386.14

Additional fiscal impact if Council elects to purchase the recycle bins= +\$24,000

Grand total fiscal impact of the extension if bins are purchased = \$194,121.16

- Critical Success Factor(s):**
- Vibrant and Diverse Cultural Opportunities
  - Thoughtful Development and Prosperous Economy
  - Safe, Welcoming, and Engaged Community
  - Inspired, Aligned, and Proactive City Leadership
  - Financial Stability
  - Quality Infrastructure, Amenities, and Services
  - Not Applicable

**Background:** Oak Creek's existing trash and recycling collection contract expires on 12-31-19. Our current contract allows for an extension for an additional two years, negotiated up to CPI. Although the contract extension for recycling is significantly higher than CPI, staff feels based on conditions in the recycling market this is a fair contract for Oak Creek. The increases of 30+% are not unique to the City of Oak Creek. According to the State of Wisconsin's DNR office for Recycling and Grant Management, communities who have recently contracted for these services are experiencing similar and even larger price increases.

This extension would also permit the City of Oak Creek to retain ownership of both trash and recycle bins. Oak Creek presently owns the trash bins used for collection, but does not own the recycle bins. As a provision of this extension, the City would be able to purchase these bins over the two year extension for \$24,000. This would equate to \$2.88 cents per bin; typically for new bins we would be paying \$60 each or a total of \$504,000. We feel that this extension will give the recycling market time to stabilize, and give Oak Creek its best opportunity for a multi-year contract in the future.

**Options/Alternatives:** Council could direct staff to continue to negotiate with Advanced or put contracts out to a competitive bidding process.

---

Respectfully submitted:



Andrew J. Vickers, MPA  
City Administrator

Prepared:

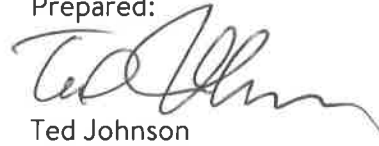

Ted Johnson  
Director of Public Works

Fiscal Review:

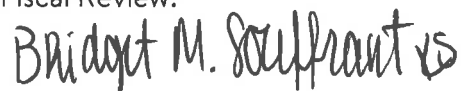

Bridget M. Souffrant  
Assistant City Administrator/Comptroller

---

**Attachments:** Refuse Contract Amendment, Recycling Contract Amendment

AMENDMENT TO CONTRACT FOR CITY OF OAK CREEK  
REFUSE COLLECTION SERVICES

THIS AMENDMENT TO CONTRACT FOR CITY OF OAK CREEK REFUSE COLLECTION SERVICES, is made and entered into this \_\_\_\_ day of September, 2019, by and between ADVANCED DISPOSAL SERVICES SOLID WASTE MIDWEST, LLC, a corporation existing under and by virtue of the laws of the State of Wisconsin, hereinafter referred to as the "Contractor" and the CITY OF OAK CREEK, a municipal corporation of the State of Wisconsin, hereinafter referred to as the "City".

The Amendment is attached to and incorporated herein by reference to the Contract Specifications City of Oak Creek Refuse Collection Services dated December 23, 2014 (the "Contract").

The Contractor and City hereby agree to amend the Contract as follows:

A. Section C.1. regarding COLLECTION shall read as follows:

"COLLECTION. Collection of non-recyclable trash shall be made weekly, with all suitable materials for collection being placed by residents at the curb of their homes by 6:45 a.m. on the day of collection. All non-recyclable solid waste, garbage and combined refuse shall be placed by residents in a blue cart which is provided and maintained by the Contractor. In addition to the 8,400 residential units, the City owned facilities attached and incorporated by reference in Exhibit B shall be included in this contract. The address of City Hall and Library is 8040 South 6<sup>th</sup> Street."

B. Section D.1. regarding TERM shall read as follows:

"TERM. The term of this Contract shall be two (2) years commencing January 1, 2020 and terminating December 31, 2021. Thereafter this Contract may be renewed for an additional term of two (2) years by mutual written agreement of the parties. The City shall provide written notice with its intent to extend the contract within 90 days prior to the expiration of the initial contract. The City and the Contractor shall negotiate any increases to fees charged for these two (2) additional years."

C. Section D.2. regarding MONTHLY COST shall read as follows:

"MONTHLY COST. The City agrees to pay the Contractor the sum of \$75,855.82 monthly for a total annual cost of \$910,269.85 for 2020 and the sum of \$78,876.00 monthly for a total annual cost of \$946,512.00 for 2021 for the services rendered pursuant to this agreement:"

D. Section D.2.a. shall read as follows:

"Refuse collection based upon 8,400 units weekly (52 annual collections per household). This unit count number is an estimate but is the agreed upon basis for



payment irrespective of the actual number of units collected and accounts for move-ins, move-outs and seasonal residents during the term of the agreement.”

E. Section D.2.b. shall read as follows:

“Payments of fees for services shall be made within thirty (30) days of the end of each month and shall be based upon 8,400 units.”

It is understood and agreed that the language and agreement contained in this Amendment shall be binding upon the parties in addition to the language of the Contract.

The parties hereto agree that all other terms and conditions of the Contract remain in full force and effect.

ADVANCED DISPOSAL SERVICES  
SOLID WASTE MIDWEST, LLC  
W144 S6350 College Ct.  
Muskego, WI 53150

CITY OF OAK CREEK  
8040 S. 6<sup>th</sup> St.  
Oak Creek, WI 53154

By: \_\_\_\_\_

By: \_\_\_\_\_  
Daniel J. Bukiewicz, Mayor

ATTEST:

\_\_\_\_\_  
Catherine A. Roeske, City Clerk

COUNTERSIGNED:

I hereby certify that sufficient funds  
are in the Treasury to meet the expense  
hereof.

\_\_\_\_\_  
Bridget M. Souffrant  
Assistant City Administrator/Comptroller

Examined and approved as to form this  
\_\_\_\_\_ day of September, 2019.

\_\_\_\_\_  
Melissa L. Karls, City Attorney

AMENDMENT TO CONTRACT FOR  
CITY OF OAK CREEK  
RECYCLABLES COLLECTION SERVICES

THIS CONTRACT, made and entered into this \_\_\_\_\_ day of September, 2019, by and between ADVANCED DISPOSAL SERVICES SOLID WASTE MIDWEST, LLC, a corporation existing under and by virtue of the laws of the State of Wisconsin, hereinafter referred to as the "Contractor" and the CITY OF OAK CREEK, hereinafter referred to as the "City".

The Amendment is attached to and incorporated herein by reference to the Contract Specifications City of Oak Creek Recyclables Collection Services dated December 23, 2014 (the "Contract").

The Contractor and City hereby agree to amend the Contract as follows:

A. Section 2 regarding TERM AND RATE shall read as follows:

"TERM AND RATE: The term of this Contract shall be two (2) years commencing January 1, 2020 and terminating December 31, 2021. Thereafter this contract may be renewed for an additional term of two (2) years by mutual written agreement of the parties. The City shall provide written notice with its intent to extend the contract within 90 days prior to the expiration of the initial contract. The City and the Contractor shall negotiate any increases to fees charged for these two (2) additional years.

The City agrees to pay the Contractor a total of \$380,016.00 annually for 2020 and a total of \$398,160.00 annually for 2021, in addition to the dumpster delivery and disposal fees sets forth in the Bid Form, attached and incorporated by reference as Exhibit A, in conjunction with the services rendered pursuant to this contract. Included with these total fees for 2020 and 2021, the City shall retain ownership of the 8,400 Contractor provided 90 gallon carts provided for each Household Unit in use at the end of the term."

B. Section 5 regarding SERVICE DETAILS shall read as follows:

"SERVICE DETAILS

- a. COLLECTION. Collection of recyclables shall be made semi-weekly on the same day as refuse collection, with all suitable materials for collection being placed by residents at the curb of their homes by 6:45 a.m. on the day of collection. All recyclables shall be placed by residents in the 90 gallon cart which is provided and maintained by the Contractor. In addition to the 8,400 Household Units, the City owned facilities listed in Exhibit C, attached and incorporated by reference, shall be included in this contract and shall have recyclables service collection on a weekly or bi-weekly basis per the schedule in Exhibit C. The address of City Hall and Library is 8040 South 6<sup>th</sup> Street."

C. Section 9 regarding PAYMENT TO CONTRACTOR shall read as follows:

PAYMENT TO CONTRACTOR: Contractor shall submit invoices directly to the City on a monthly basis for its services rendered hereunder. Charges shall be based on the number of Household Units within the City. As of the commencement of this Contract, the number

of Household Units within the City is 8,400, subject to verification by Contractor (the "Unit Count"). The Unit Count shall be updated annually during the term of this Contract based on any new or removed Household Units. In the event of any dispute regarding the Unit Count, a physical unit count of the number of Household Units within the City shall govern. The City shall pay Contractor the full amount invoiced, regardless of the amount actually collected by City from Household Units no later than 30 days following the date of Contractor's invoice.

It is understood and agreed that the language and agreement contained in this Amendment shall be binding upon the parties in addition to the language of the Contract.

The parties hereto agree that all other terms and conditions of the Contract remain in full force and effect.

ADVANCED DISPOSAL SERVICES  
SOLID WASTE MIDWEST, LLC  
W144 S6350 College Ct.  
Muskego, WI 53150

CITY OF OAK CREEK  
8040 S. 6<sup>th</sup> St.  
Oak Creek, WI 53154

By: \_\_\_\_\_

By: \_\_\_\_\_  
Daniel J. Bukiewicz, Mayor

ATTEST:

\_\_\_\_\_  
Catherine A. Roeske, City Clerk

COUNTERSIGNED:

I hereby certify that sufficient funds are in the Treasury to meet the expense hereof.

\_\_\_\_\_  
Bridget M. Souffrant  
Assistant City Administrator/Comptroller

Examined and approved as to form this  
\_\_\_\_\_ day of September, 2019.

\_\_\_\_\_  
Melissa L. Karls, City Attorney

## COMMON COUNCIL REPORT

**Item:** Install Exterior Electric at Lake Vista Park

**Recommendation:** To approve the installation of additional electrical service for the Lake Vista Park pavilion exterior area, to be installed by Pieper Power in the amount of \$21,350.00.

**Fiscal Impact:** This will be paid for out of the project budget 17024 Street Light & Traffic Signal Maintenance Account.

**Critical Success Factor(s):**

- Vibrant and Diverse Cultural Opportunities
- Thoughtful Development and Prosperous Economy
- Safe, Welcoming, and Engaged Community
- Inspired, Aligned, and Proactive City Leadership
- Financial Stability
- Quality Infrastructure, Amenities, and Services
- Not Applicable

---

**Background:** Currently the main pavilion at Lake Vista Park only has one twenty-amp exterior outlet. This has proven to be inadequate to power the beer trailer, let alone a band and other items that require power during special events. In order to accommodate events, we have had to rent generators and run extension cords. As this site becomes utilized more for special events, we will need to upgrade the exterior service.

**Options/Alternatives:** Do nothing and continue to use generators.

---

Respectfully submitted:



Andrew J. Vickers, MPA  
City Administrator

Prepared:

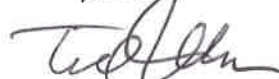

Ted Johnson  
Director of Public Works

Fiscal Review:

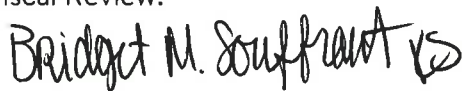

Bridget M. Souffrant  
Assistant City Administrator/Comptroller

---

**Attachments:** Contractor Quotes



4085 North 128th Street, Brookfield, WI 53005  
phone 262.781.1500 · fax 262.781.1540  
www.LembergElectric.com

April 1, 2019

City of Oak Creek  
ATTN: Steve Kohnke

Steve,

Lemberg Electric is pleased to provide you with the following quote, based on our discussion:

#### Lake Vista Park

- Furnish and Install the following equipment:
- (1) 125-amp circuit breaker in existing gear
- (50') 2" EMT conduit and wiring from panel to exterior wall
- (1) block wall penetration and sealing
- (1) 125-amp 3R three-phase panel (#1) with circuit breakers on building
- (130') 1-1/2" PVC conduit and wiring from panel #1 to panel #2 bored
- (1) 100-amp 3R three-phase panel (#2) with circuit breakers
- (190') 1" PVC conduit and wiring from panel #1 to panel #3 bored and plowed
- (1) 70-amp 3R three-phase panel (#3) with circuit breakers
- Include (3) 24" x 2' concrete bases with 2" IMC conduit for supporting panels
- (75') 3/4" PVC conduit and wiring from panel #2 to benches
- (4) Double GFCI receptacles with lockable in-use covers on benches
- (1) Double GFCI receptacles with lockable in-use covers at panel #1
- (1) 50-amp twistlock receptacle in 3R box at panels #2 and #3

**Price for providing above**

**\$32,710.00**



4085 North 128th Street, Brookfield, WI 53005  
phone 262.781.1500 - fax 262.781.1540  
www.LembergElectric.com

#### NOTES

- 1 Work to be performed during normal working hours (6AM-4PM)
- 2 Excavated areas returned to rough grade (topsoil, seed by others)
- 3 All wire is one size larger to compensate for voltage drop
- 4 Electrical permit and inspection fees are not included

Thank you for the opportunity to provide you with this pricing. Feel free to call me with any questions you might have.

Sincerely,

A handwritten signature in black ink, appearing to read "Matt Schmidt".

Matt Schmidt  
Lemberg Electric Company, Inc.  
Direct 262-364-0366



PIEPER ELECTRIC, INC. | Solutions Powered by People Since 1947

September 10, 2019

City of Oak Creek  
Attn: Ted Johnson  
800 W. Peutz  
Oak Creek, WI 53154

RE: Lake Vista Park outdoor electrical.

Mr. Kohnke,

We will provide labor, material, tools, and supervision to perform the following work:

- Provide and install (1) 125A 3 pole breaker in the service.
- Provide and extend a 2" conduit with a 125A feeder from the service panel to a location on the back side of the building.
- Provide and install a 125A 120/208V 3R panelboard on the exterior of the back side of the building and terminate the feeder.
- Provide and install (1) 100A 3 pole breaker in panelboard 1.
- Provide and install approximately 170' of 1 ½" HDPE from the 125A panelboard to the 2<sup>nd</sup> panelboard.
- Provide and install a 24" diameter base and 2" RMC to support panelboard 2.
- Provide and install 100A wiring and terminate the feeder in panelboard 2.
- Provide and install (1) 70A 3 pole breaker in panelboard 2.
- Provide and install approximately 110' of 1" HDPE from panelboard 2 to the 3<sup>rd</sup> panelboard.
- Provide and install a 24" diameter base and 2" RMC to support panelboard 3.
- Provide and install 70A wiring and terminate the feeder in panelboard 3.
- Extend ¾" HDPE conduit from panelboard 2 to provide (4) double duplex GFCI receptacles with in use covers on (2) benches.
- Provide and install (1) double duplex GFCI receptacle with in use covers on both panelboard 2 and 3.
- Provide and install (1) 50A 120/240 twist lock receptacle with in use covers on both panelboard 2 and 3.

**Price for the above work: \$21,350.00**

Notes:

- All work performed during straight time hours unless otherwise noted.
- Price includes directional boring and plowing of HDPE conduit.
- Site will be restored to grade but restoration not included.
- All outdoor conduit above grade is RMC.
- Not responsible for existing code violations.
- City permit included.



We thank you for giving us the opportunity of estimating this work, and should there be any questions, please do not hesitate to contact me at 262-374-2393.

Sincerely,  
**Pieper Electric, Inc.**

*Jeffrey Malaney*  
Jeffrey Malaney

NOTE: This proposal is valid for 30 days, negotiable thereafter.

Date Accepted: \_\_\_\_\_  
By: \_\_\_\_\_





## TERMS AND CONDITIONS OF SALE

- 1. LIEN NOTICE.** As required by the Wisconsin Construction Lien Law, Seller (Pieper Electric, Inc. and all DBAs) hereby notifies Owner that persons or companies furnishing labor or materials for the construction on Owner's land may have lien rights on the Owner's land and buildings if not paid. Those entitled to lien rights, in addition to Seller, are those who contract directly with the Owner or those who give the Owner notice within sixty (60) days after they first furnish labor or materials for the construction. Accordingly, Owner will probably receive notices from those who furnish labor or materials for the construction, and should give a copy of each notice received to his mortgage lender, if any. Seller agrees to co-operate with the Owner and his lender, if any, to see that all potential lien claimants are duly paid.
  - 2. ENTIRE AGREEMENT.** This Agreement constitutes the entire contract for material, work, and other goods and services (collectively "Goods") between the Seller and the Buyer ordering such Goods ("Buyer"). It is expressly agreed that no statement, arrangement, warranty, or understanding, oral or written, expressed or implied, will be recognized unless it is stated in, or otherwise permitted by, this Agreement. This Agreement is solely for the benefit of Buyer and Seller, and is not intended for the benefit of any other party.
  - 3. PROPOSAL.** Seller is responsible for, and shall have sole control of, the construction methods, sequences and coordination of all work described in the Proposal, unless expressly stated to the contrary. Any items not listed are not included in the Agreement price and shall be the obligation of the Buyer.
  - 4. CONSTRUCTION MATERIALS.** All materials and work shall be furnished in accordance with normal industry tolerances for color, variation, thickness, size, weight, amount, finish, texture and performance standards. Excess materials delivered to job site and/or materials not physically attached to the structure after substantial completion of the work contemplated by this Agreement shall remain the property of Seller.
  - 5. ACCESS TO WORK AND SITE.** Buyer shall provide electric power, water, telephone and toilet facilities for use by Seller and its subcontractors/employees. Storage of materials and storage of Seller's equipment shall also be provided by Buyer. All utility connections and service charges, if any, shall be paid by the Buyer. Furthermore, Buyer agrees to maintain access for Seller at the Project Site to keep Project Site free from obstructions and conflicting work, and to obtain permission for Seller to gain access through adjacent property, if required by Seller to do so. Buyer shall be solely responsible for all risk, shall hold Seller harmless and free of liability, and shall compensate for any damages or costs arising out of such access or the failure to maintain access, except to the extent due to the intentional acts of Seller, its agents and/or employees.
  - 6. INSURANCE.** Seller shall maintain workers' compensation, automobile liability, commercial general liability and such other insurance as required by law. Seller will furnish a Certificate of Insurance evidencing the types and amounts of its coverage, upon request. Buyer shall maintain insurance covering all physical loss expressly including, but not limited to, coverage for collapse, fire, wind damage, theft, vandalism and malicious mischief, naming Seller as additional insured. Buyer assumes risk of loss during construction, except for the intentional acts of Seller, its subcontractors or employees.
  - 7. ENVIRONMENTAL HAZARDS.** Seller is not responsible for any environmental hazards. The Buyer shall be solely responsible for all risk, shall indemnify and hold Seller harmless and free of liability, and shall bear the costs of any removal or correction of environmental materials.
  - 8. SITE CONDITIONS.** Seller shall not be responsible for additional costs due to the existence of latent conditions that are not disclosed in writing to Seller. The raising, disconnection, re-connection or relocation of any mechanical equipment that may be necessary for Seller to perform the work shall be performed by others or treated as an extra.
  - 9. PAYMENT.** Buyer shall timely make all payments required by this Agreement. Time is of the essence as to all terms of payment. Buyer agrees that, in addition to other remedies available to Seller, if payment is not timely made, Seller shall be entitled to a service charge of 1.0% per month on all past due amounts, plus, if not contrary to any law, all costs of collection including actual attorneys' fees. Seller shall furnish lien waivers to Buyer at the time each Progress Payment and the Final Payment is made to Seller for the proportionate value of all Goods ordered or delivered as of the time the payment is made. Final Payment shall constitute acceptance and approval of all work, and a waiver of all claims by Buyer, except those arising from liens or the warranty included in this Agreement. No retention shall apply to any of the work.
  - 10. JOB SIGN.** Buyer agrees to allow Seller to display a construction sign at the Project Site.
  - 11. CHANGES.** No changes, additions, alterations, deviations or extras to the Plans and Specifications shall be made without a written Change Order signed by the Buyer and Seller in advance, which will be performed based on Seller's standard time and material rates. Notwithstanding, Buyer's signature shall not be required for changes necessary to conform to codes, laws or regulations required by any utility or governmental authority, or to address existing conditions of the Project Site unknown to Seller at the time Seller signs this Agreement. All Change Orders shall be incorporated as part of this Agreement. Upon Seller's request, Buyer agrees to pay for all changes in advance of each change being commenced. Buyer understands and agrees that changes will extend the time of performance by at least 5 work days for each change unless otherwise agreed in writing.
  - 12. WORK STOPPAGE.** Should work be stopped by any public authority or the Buyer for more than thirty calendar days, Seller may terminate this Agreement and collect for the value of all work completed and materials ordered as of the date work is stopped, plus Seller's anticipated profit under this Agreement. Buyer's failure to sign Change Orders or Buyer's refusal to make progress payments, or any other cause beyond Seller's sole control, shall also be cause for work stoppage by Seller.
  - 13. DELAY.** Work shall be completed within the number of working days stated in this Agreement, unless delay occurs due to work stoppage, adverse weather conditions, labor disputes, changes by Buyer, work performed by Buyer (or Buyer's separate contractors) or governmental authorities, unavailability of materials or supplies, unavoidable casualties, accidents, environmental hazards, Buyer's failure to make payments as required by this Agreement, or any other cause beyond Seller's sole control. Any such delay shall extend the time of performance or, at Seller's Option, terminate this Agreement if the cause of the delay cannot be resolved within thirty calendar days. Where Seller elects to extend performance, Seller shall also be entitled to additional payment to reflect any increased cost of labor and/or materials. Seller will give notice to Buyer of delay and any adjustments to time of performance or cost of the work necessitated by the delay.
  - 14. DISPUTES.** These Terms shall be deemed to have been made in and governed by the laws of the State of Wisconsin. Any legal suit or action with regard to these Terms or the Project hereunder may, at Seller's option, be venued in Milwaukee County Circuit Court, Wisconsin. Seller may also, at Seller's sole discretion, elect arbitration and/or mediation in place of civil litigation, without regard to whether litigation has been commenced by Buyer. If an Arbitrator cannot be agreed upon, Seller can petition Circuit Court for same.
  - 15. WARRANTY.** Seller warrants and guarantees to Buyer that all material and equipment, and the work to be performed hereunder, will be of good quality and free from faults and defects. This warranty shall cover material (except lamps and other expendables) for the manufacturer's stated warranty period and workmanship for one year from the date of substantial completion. This warranty does not apply to bid work if the bid documents stipulate a lesser warranty. This warranty is in lieu of all other warranties, express or implied, of merchantability, fitness for a particular purpose, performance, or otherwise. Seller's liability under the warranty is strictly and exclusively limited to the repair or replacement at the job site of such work (including material and equipment) as is found to be defective within such warranty period, and with respect to which the Buyer has given Seller prompt written notice within such period. No allowance will be made for repairs or alterations unless made with Seller's prior written consent or approval. In no event shall Seller be liable for claims for any other damages based upon breach of express or implied warranty or negligence whether direct, immediate, foreseeable, consequential or special. This paragraph states Seller's entire liability with respect to warranties, guarantees, or representations, express or implied. Seller will be held harmless against claims, damages, losses and expenses, including attorneys' fees arising from work not done by Seller's own workforce.
  - 16. CONFLICTS/INCONSISTENCIES.** If any inconsistency or ambiguity is believed to exist among any of the documents comprising the contract, the inconsistency or ambiguity shall be resolved by applying the following order of precedence: (a) this Agreement including these Terms and Conditions; (b) the plans and specifications, if any; (c) other documents comprising the contract, if any.
  - 17. ASBESTOS AND TOXIC MATERIALS.** This proposal and contract is based upon the work to be performed by Seller not involving asbestos-containing or toxic materials and that such materials will not be encountered or disturbed during the course of performing the work. Seller is not responsible for expenses, claims or damages arising out of the presence, disturbance, or removal of asbestos-containing or toxic material. In the event that such materials are encountered, Seller shall be entitled to reasonable compensation for all additional expenses incurred as a result of the presence of asbestos-containing or toxic materials at the work site.
  - 18. PROTECTION OF PERSONAL PROPERTY AND PROJECT SITE.** Buyer agrees to remove or protect any personal property inside and outside the Project Site. Seller shall make reasonable efforts to avoid damage to existing property. Seller will make every effort to keep dust down to a bare minimum. Seller is not responsible for housecleaning or damages during normal construction activities.
  - 19. IMPAIRMENT OF CREDIT.** If Buyer is or becomes insolvent, or is unable to pay his debts as they mature, or files or has filed against him a bankruptcy, insolvency, or similar petition or fails to pay any debt arising hereunder to Seller on time, or if Seller in good faith doubts the ability of Buyer to pay, Seller may, at its option, either: (a) terminate the work at any time thereafter, and Buyer shall thereupon pay for all work performed on a pro-rata basis plus all lost profit or (b) discontinue work until such time as the Buyer has paid Seller in full for work performed, has agreed to pay Seller for any additional costs incurred because of such discontinuance, and upon such other terms or conditions as may be imposed by Seller to ensure the payment for the work.
  - 20. HOLD HARMLESS.** Seller will hold harmless and defend Buyer against any claims brought by a third party for damages or losses arising out of Seller's performance of work under this contract provided that the third party claim is attributable to bodily injury or death, or injury to or from destruction of tangible property, but only to the extent caused by the negligence of Seller or Seller's subcontractors and not caused in whole or in part by the Buyer or its agents, employees or representatives. Seller shall not be liable for any consequential damages claimed by any party including, but not limited to, lost profits, loss of use, or attorney's fees. As conditions precedent to Seller's duties under this provision, Buyer must (a) provide Seller with written notice of any claim against Buyer immediately after Buyer is aware of the claim; and (b) remain current with all of Buyer's obligations under this contract. This provision is null and void if the Buyer fails to perform any of its obligations under this contract. Seller shall have the sole right to manage the defense of the claim or resolve the claim. Buyer agrees to fully cooperate with Seller in the investigation and defense of any claim brought by another party.
  - 21. WORKING HOURS.** Unless specifically noted, all work included in this contract is to be performed during normal business hours, Monday through Friday. Work performed at any other time, or on legal holidays, will result in an extra charge to Buyer.
- GENERAL EXCLUSIONS.** Seller shall not be responsible for coordinating or supervising work performed by Buyer's own forces or contractors. Seller shall be entitled to an equitable adjustment for hidden or latent conditions. Cost of pumping water from basements and other excavations is not included in quotation. Any alteration or deviation from the specifications as outlined on reverse involving extra cost of material or labor will only be executed upon written orders for same and will become an extra charge over the sum mentioned in this contract. Seller is not responsible for damage to underground services. Any changes in local or state codes effective after date of proposal will be charged as an extra or credited as the case may be. Patching of walls and floors is to be done by others unless specifically stated in this contract as Seller's responsibility.

## COMMON COUNCIL REPORT

**Item:** License Committee Report

**Recommendation:** That the Common Council grant the various license requests as listed on the 9/17/19 License Committee Report.

**Fiscal Impact:** License fees in the amount of \$670.00 were collected. Additional fees in the amount of \$10,506.29 will be collected prior to the release of the Reserve Class B Combination alcohol license.

**Critical Success Factor(s):**

- Vibrant and Diverse Cultural Opportunities
- Thoughtful Development and Prosperous Economy
- Safe, Welcoming, and Engaged Community
- Inspired, Aligned, and Proactive City Leadership
- Financial Stability
- Quality Infrastructure, Amenities, and Services
- Not Applicable

---

### Background:

The License Committee met on 9/12/19. Minutes are attached. Recommendations are as follows:

1. Grant an original Operator's license to Ashley N. Pientka, 1631 Rolling Green Dr., Racine (Charcoal Grill).
2. Grant a renewal Operator's license to Nicholas Baumann, 8575 S. Orchard View Ln., Oak Creek (Water Street Brewery).

The following items were received after the License Committee met. Tentative recommendations are as follows:

1. Grant an Operator's license to:
  - \* Cynthia A. Konieczki, 1308 Marion Ave., South Milwaukee (Gastrau's Golf Center)
  - \* Jazmin I. Rivera, 3821 E. American Ave., Oak Creek (Kwik Trip)
  - \* Kelli J. Gish, 707 Columbia Ave., South Milwaukee (Walgreens)
  - \* Krystal R. Kavanaugh, 2654 N. Bremen St., Milwaukee (Bel Air Cantina)
2. Grant a 2019-20 Reserve Class B Combination alcohol license to Alketi Ago, Agent, A1 Investments LLC dba Sports Café, 928 E. Rawson Ave., with release of license subject to final inspection approvals and receipt of any fees due.
3. Grant a change of agent to Apple Hospitality Group, LLC dba Applebee's Neighborhood Grill & Bar, 7135 S. 13<sup>th</sup> St., from Jeremiah Smith to Carrie Hedl, 5787 S. Swift Ave., Cudahy.

---

4. Grant a Temporary Class B Beer license to Duane Haas, Agent, St. Matthews School, 9303 S.Chicago Rd., for the St. Matthews Adult Field Day event to be held on 9/21/2019.

5. Grant a Special Event Permit to Sheryl Briley, Agent, South East Wisconsin Young Marines, for the Young Marines 3<sup>rd</sup> Annual DDR Dash 5k Run/Walk to be held on October 12, 2019.

**Options/Alternatives:** None

---

Respectfully submitted:

Prepared:



Andrew J. Vickers, MPA  
City Administrator



Christa J. Miller, CMC/WCMC  
Deputy City Clerk

Fiscal Review:



Bridget M. Souffrant  
Assistant City Administrator/Comptroller

---

Attachments: None

**MINUTES  
LICENSE COMMITTEE  
September 12, 2019 at 8:30 a.m.**

1. The meeting was called to order at 8:30 a.m.
2. On roll call, the following committee members were present: Ald. Kurkowski and Ald. Gehl. Ald. Duchniak was excused. Also in attendance was Deputy City Clerk Christa Miller.
3. Ald. Gehl, seconded by Ald. Kurkowski, moved to approve the minutes of 5/9/19. On roll call, all voted aye.
4. The Committee reviewed an original application for an Operator's license submitted by Ashley Pientka, 1631 Rolling Green Dr., Racine (Charcoal Grill). Ms. Pientka was in attendance.

On her application, Ms. Pientka listed prior convictions. In addition to being convicted of eight felonies, Ms. Pientka omitted thirteen convictions, which could constitute falsification by omission, however, due to the nature of the convictions, Ms. Pientka does not appear to be a habitual offender.

Ms. Pientka was asked about her conviction record and she indicated that in 2013 and 2014 she was heavy into drugs and it took over her life. She indicated that after her last arrest in 2014, she got clean and has been sober for nearly 3 years.

Ms. Pientka advised the Committee that she has been employed since mid-2018 with her employer, Charcoal Grill, and recently, in February of 2019, she was promoted to manager.

Ald. Gehl, seconded by Ald. Kurkowski, moved to approve the original application for an Operator's license submitted by Ashley Pientka, 1631 Rolling Green Dr., Racine (Charcoal Grill). On roll call, all voted aye.

5. The Committee reviewed a renewal application for an Operator's license submitted by Nicholas J. Baumann, 8575 S. Orchard View Ln., Oak Creek (Water Street Brewery). Mr. Baumann was in attendance.

Mr. Baumann disclosed an OWI from 2017 and an Underage Consumption conviction from 2014.

In addition to the disclosed convictions, Mr. Baumann's background report also showed an additional underage consumption conviction from 2016.

Mr. Baumann indicated that he did not intend to omit the additional underage consumption conviction, noting that he had included it in his original application, but just forgot there were 2 priors when completing the renewal application.

Ald. Gehl, seconded by Ald. Kurkowski, moved to approve the renewal application for an Operator's license submitted by Nicholas J. Baumann, 8575 S. Orchard View Ln., Oak Creek (Water Street Brewery). On roll call, all voted aye.

Ald. Gehl, seconded by Ald. Kurkowski, moved to adjourn this meeting at 8:46 a.m. On roll call, all voted aye.

## COMMON COUNCIL REPORT

**Item:** Vendor Summary Report

**Recommendation:** That the Common Council approve the September 11, 2019 Vendor Summary Report in the total of \$358,701.48.

**Fiscal Impact:** Total claims paid of \$358,701.48.

**Critical Success Factor(s):**

- Vibrant and Diverse Cultural Opportunities
- Thoughtful Development and Prosperous Economy
- Safe, Welcoming, and Engaged Community
- Inspired, Aligned, and Proactive City Leadership
- Financial Stability
- Quality Infrastructure, Amenities, and Services
- Not Applicable

---

**Background:** Of note are the following payments:

1. \$5,718.00 to Baker Tilly (pgs #2-3) for services in connection to 2018 audit.
2. \$25,941.94 to Enterprise FM Trust (pgs #4-5) for DPW vehicle lease monthly payment.
3. \$12,000.00 to Faith Baptist Church (pg #1) for BD Bond Refund.
4. \$12,454.60 to Kansas City Life Insurance Co. (pg #8) for October disability insurance.
5. \$18,518.10 to Savage Solutions, LLC (pg #13) for marketing and advertising services and retainer fees. (Tourism)
6. \$9,268.65 to Sovos Compliance, LLC (pg #14) for Taxport ACA and TIR ACA Manager.
7. \$6,996.25 to Stantec Consulting Services (pg #14) for consulting related to former Oak Creek Storage and Handling.
8. \$6,514.50 to WDATCP-DFRS (pg #16) for 2018-2019 licensing fees.
9. \$60,898.43 to US Bank (pgs #21 - 31) for equipment and vehicle maintenance, travel and training, supplies, building maintenance, dues and publications, license fees, data lines, Verizon phone services, legal notices, and office supplies.
10. \$16,981.09 to WE Energies (pgs #16-17) for street lighting, electricity & natural gas.
11. \$12,618.85 to WI Court Fines & Surcharges (pg #17) for August court fines.
12. \$24,515.39 to WI Dept. of Transportation (pg #17) for permits for Ryan Road ramps.
13. \$21,202.53 to WI Park & Rec Association (pg #18) for WPRAs summer ticket discount program.
14. \$16,806.33 to World Fuel Services, Inc. (pg #18) for fuel inventory.

---

Options/Alternatives: None

---

Respectfully submitted:



Andrew J. Vickers, MPA  
City Administrator

Prepared:



Kristina Strmsek  
Staff Accountant

Fiscal Review:



Bridget M. Souffrant  
Assistant City Administrator/Comptroller

---

Attachments: 9/11/19 Invoice GL Distribution Report